

Sevenoaks District Council

Environmental Health

Annual Report

2008 - 2009

Contents

1.0 Introduction	3
1.1 Service Aims	3
1.2 Enforcement Policy	3
1.3 Environmental Health Team Structure	3
1.4 Event Management	4
2.0 The Environmental Protection Team	4
2.1 List of Functions	4
2.2 Statutory Nuisance	5
2.3 Rubbish and Rodents	6
2.4 Local Air Quality Management	6
2.5 Industrial Air Pollution	6
2.6 Contaminated Land	6
2.7 Drainage and Sewage	7
2.8 Dog Control Service	7
2.9 Animal Welfare Licensing	7
2.10 Planning and Licensing Consultations	8
2.10.1 Planning	8
2.10.2 Licensing	8
2.11 Antisocial Behaviour	8
2.12 High Hedges	9
2.13 Out of Hours Service	9
3.0 The Commercial Team	9
3.1 List of Functions	9
3.2 Health and Safety Enforcement	10
3.3 Flexible Warranting Scheme	10
3.4 Skin Piercing	11
3.5 Accident at Work Reports	11
3.6 Smoke Free Enforcement	12
3.7 Infectious Disease Control	12
3.8 “Safer Food Better Business”	13
3.9 Training Partnership	14
3.10 Scores on the Doors	14
3.11 Reach for the Stars Seminar	14
3.12 Food Sampling	15
3.13 Private Water Supplies	15
4.0 Team Achievements 2008 – 2009	16
Appendix A	17
Environmental Health Organisational Structure	18

1.0 Introduction

Welcome to the second Environmental Health Annual Report.

Following a successful management review in 2006, the two teams that make up the Environmental Health Team have continued to demonstrate improvements with efficiencies and quality on the service that they provide to the public.

The work that is carried out by the team is all Public Health related and has a positive impact, both directly and indirectly on all people who live, work and visit the Sevenoaks district.

To avoid duplication, it is intended that this report is to be read in conjunction with the Food Service Plan for the Food Standards Agency 2009-10. A number of service areas which are included in this report are expanded upon in the Environmental Health Annual Report.

1.1 Service Aims

- To meet statutory responsibilities in a cost effective and responsible manner
- To promote public health initiatives
- To provide exemplary customer service

1.2 Enforcement Policy

All enforcement work is performed in accordance with our Council agreed Enforcement policy, which can be viewed on the council website, www.sevenoaks.gov.uk/housing/447.asp. The Council has also signed up to the Enforcement Concordat. Work is monitored against this policy to ensure that enforcement is fair and proportionate.

1.3 Environmental Health Team Structure

Environmental Health consists of two teams - Environmental Protection Team and the Commercial Team. Organisational structure charts are attached in Appendix A.

1.4 Event Management

Environmental Health co-ordinates the Council's response to major events within the District, this includes liaison with private sector housing for camping issues, the licensing section where the event is licensed and building control with respect to temporary structures. Environmental health monitor noise issues and food and health and safety standards at events and chairs and organises the Brands Hatch Safety Advisory Group which meets on a quarterly basis.

Events include the World and British Super Bikes and other motor racing events at Brands Hatch Racing Circuit, concerts at Penshurst Place and the European Golf Open at the London Golf Club, Ash.

2.0 The Environmental Protection Team

The Environmental Protection team is responsible for delivering a wide range of statutory environmental services in order to protect public health and reduce harm to the environment.

The team comprises 9 full time staff including the animal welfare officer and in 2008 responded to over 2656 service requests.

The team works closely with other sections of the council, particularly Development Control, Community Development and Licensing. They also liaise with many other outside organisations such as the Environment Agency, West Kent Mediation Service and West Kent Housing Association.

2.1 List of Functions

Principle service areas include:

- Statutory Nuisance investigations arising from:
 - Noise
 - Premises
 - Smoke
 - Fumes and gases
 - Odour
 - Dust and steam
 - Accumulations and deposits
 - Animals
 - Insects
 - Artificial light

- Rubbish and Rodents

- Local Air Quality management
- Industrial air pollution control
- Contaminated land
- Drainage and sewage
- Dog control service covering:
 - Stray dogs
 - Lost, found and stolen dogs
 - Micro chipping
 - Promotion of responsible dog ownership
- Animal welfare licensing
- Planning and Licensing consultations
- Anti-Social behaviour covering:
 - Noise
 - Littering
 - Fixed Penalty Notices
 - Dog fouling
 - Vicious dogs
- High Hedges
- Out of hours Environmental Health service
- Providing general advice on wide range of pollution issues:
 - Radon
 - Smoke Control Areas
 - Invasive Plants such as Japanese knot weed
 - Asbestos
 - Polluting vehicles
 - Environmental consultations and searches

2.2 Statutory Nuisance

To be a Statutory Nuisance something must be either Prejudicial to Health or a Nuisance.

A Nuisance must generally be persistent, unreasonable, substantial and affect the use and quiet enjoyment of the complainant's home and property. As a result a one off bonfire or noisy party would not normally be considered a Statutory Nuisance.

Noise is the most frequently complained of nuisance issue. The team can deal with both domestic and commercial sources and has equipment to both measure and record noise if necessary.

Table 1. Number and types of noise complaints investigated

Principle Noise Sources	2007	2008
Domestic premises	191	215
Commercial and	192	128

industrial premises		
Construction sites	30	45
Barking Dogs	104	94
Defective alarms (House and car)	32	53
Noise from entertainment	19	13
Noise from railways and traffic	12	10
Noise from equipment in streets	9	2
Total	589	560

2.3 Rubbish and Rodents

The team investigated 197 rubbish complaints in 2008, this was a 34% increase on the number received in 2007. Such accumulations frequently attract rodents

2.4 Local Air Quality Management

Air quality is formally reviewed and assessed during a series of three yearly rounds. When it is confirmed that the public are exposed to high levels of certain pollutants, an Air Quality Management Area (AQMA) must be declared. The district currently has eleven AQMAs following exceedance of the National air quality objectives for Nitrogen Dioxide and PM10 (Fine Particulates). An Air Quality Action Plan outlining a number of measures and actions aimed at reducing pollution levels within the AQMAs and across the District has just been produced.

High pollution levels are caused mainly by traffic congestion especially involving HGV's and from the M25, M26, M20 and A20 (T) Swanley bypass.

Nitrogen Dioxide levels are monitored monthly at 80 locations across the District. There are also two Continuous Air Quality Monitoring Stations which measure Nitrogen Dioxide, Carbon Monoxide, PM 10 and Ozone. These are situated at Bat & Ball which provides road side pollution information and Greatness Playing fields which measures background levels.

2.5 Industrial Air Pollution Control

The council has issued 38 permits to regulate certain industries within the district which have the potential to emit pollution into the air. These include vehicle re-spraying operations, dry cleaning establishments, petrol stations. mineral processing and cement and concrete batching plants.

2.6 Contaminated Land

Local authorities are the main regulators of contaminated land and the Council has identified over 700 sites potentially contaminated sites across the

district. The vast majority of contaminated land sites are remediated through the Planning process with the team scrutinizing and commenting on applications.

The team also deals with Environmental searches and general enquires regarding land contamination.

2.7 Drainage and Sewage

Drainage issues are an increasing problem and can be complex and difficult. There can also be confusion as to the responsibility for maintenance of sewers and drains.

The Council has no direct responsibility for foul water drains, sewers, septic tanks, cesspits etc. but will ensure that the person (s) responsible take appropriate remedial action if a drainage problem (e.g. a sewer blockage causing leakage) presents a risk to public health.

Table 2 . Number of drainage service requests investigated from both domestic and commercial premises

	2007	2008
Total Drainage cases	149	166

2.8 Dog Control Service

The service promotes responsible dog ownership and deals with dog related issues including stray and lost dogs, dog fouling, re-homing and out of control and in some cases vicious dogs. Micro-chipping can also be undertaken.

Table 3. Number and types of dog service request received and investigated

Dog service requests	2007	2008
Strays	55	83
fouling	114	119
Vicious dogs	73	80
Found dogs	174	296
Lost dogs	178	293
Stolen dogs	6	4
Micro-chipping	45	17
Miscellaneous	18	11
Total	663	903

2.9 Animal Welfare Licensing

Pet shops, boarding kennels, dog breeders, catteries and horse riding establishments must all be licensed annually by the local authority. They must

meet strict guidelines set out to provide the best care for the animals and for the staff who work with them as well as ensuring the safety of the public visiting the premises.

There are 43 premises requiring licences including Eagle Heights which is classed a Zoo.

Table 4. Number and types of animal welfare establishments which require a licence.

Pet shops	14
Dog boarding establishments	4
Cat boarding establishments	6
Dog and cat boarding establishments	8
Riding Establishments	8
Dog breeder	2
Zoo	1

2.10 Planning and Licensing Consultations

We are consulted by Planning Authorities (SDC and KCC), the Environment Agency and Licensing about applications for developments or licenses that may have an impact on the local community or the environment.

2.10.1 Planning

The team will recommend appropriate conditions and/or refusal with respect to: noise – including vibration, air quality, contaminated land and other environmental health issues such as fume and odour, dust, artificial lighting and animal welfare issues.

Consultations can involve extensive and complex assessments and liaison with other agencies.

The team commented on 244 planning applications in 2008. This was a 38.5% reduction on the number of consultations from the previous year.

2.10.2 Licensing

The team is a statutory consultee on all applications made under the Licensing Act 2003 and responded to 54 premises Licence applications during 2008. This included recommending conditions to help prevent nuisance from regulated entertainment.

2.11 Anti-Social Behaviour

The team deals with varying types of anti-social behaviour, particularly relating to noise, dog fouling and littering and works closely with the

Community Development team and other agencies and residents to corporately minimise its impact.

2.12 High Hedges

The team administers and enforces the High Hedges legislation and determines complaints by the owners or occupiers of domestic properties who are adversely affected by evergreen hedges over 2 meters high.

2.13 Out of Hours service

The council provides an emergency environmental health out of hours service which provides specialist and professional advice to telephone enquiries and responds to serious incidents as well as monitoring some ongoing cases. The majority of calls relate to noise.

The out of hours service received 597 calls during 2008

3.0 The Commercial Team

The Commercial Team enforces food safety legislation in food businesses to ensure, so far as reasonably practicable, that they are hygienic and that food purchased and/or produced in the area is safe to eat. The team also enforces health and safety legislation in work places where we are the enforcing authority to ensure compliance.

The team comprises five full-time and three part-time officers. Agency staff may be used to carry out a small proportion of lower risk inspections and an externally funded Smoke free Officer works within the team on a temporary basis.

Officers liaise with colleagues in Planning, Building Control, Private Sector Housing, Licensing and Tourism on a regular basis. In order to ensure that enforcement action taken and delivery of the service is consistent with that of other local authorities in Kent, officers attend the Kent Food Group, Kent Infection Control Committee and the Kent Health & Safety Liaison Group meetings.

3.1 List of Functions

- Programmed Food Safety inspections
- Advice to prospective food business operators and inspection of new premises
- To promote Safer Food Better Business
- Microbiological sampling of food and food premises
- Provision of CIEH Food Safety and Health & Safety courses
- Controlling food poisoning outbreaks
- Investigating food poisoning notifications

- Action FSA food alerts
- Imported food
- Private water supply sampling
- Programmed Health and Safety inspections
- Health and Safety Targeted Projects
- Accident investigation
- Registration of premises/operators for acupuncture, tattooing, skin piercing and beauty treatments
- The registration of cooling towers and evaporative condensers in premises
- Dealing with service requests relating to food safety including food complaints and health & safety issues

3.2 Health and Safety Enforcement

The Commercial Team enforces Health and safety legislation where SDC is the enforcing authority. To achieve this the team undertake a planned programme of inspections of commercial premises using risk based priority planning systems. High risk premises are inspected at a determined frequency and questionnaires are sent out to low risk premises. By monitoring return of questionnaires appropriate follow up action is taken. If a health and safety inspection of a food business is due at the same time as a food inspection, a combined inspection will be carried out.

Table 5: Number of Health and Safety inspections carried out and questionnaires sent

	High Risk Inspections	Questionnaires
06/07	18	183
07/08	15	111
08/09	13	156

The team also responds to complaints and provides advice to businesses.

3.3 Flexible Warranting Scheme

As from October 2008 Officers have been authorised to carry out health and safety enforcement work under the 'Kent Flexible Warranting Initiative'. All Kent authorities and the Health & Safety Executive (HSE) are now able to work in partnership carrying out enforcement work in each others enforcement areas. This partnership is providing valuable training opportunities for officers and allowing more effective enforcement.

Two successful projects have now taken place

- The CAKE project (Common Approach to Kent Enterprises) when work places on industrial estates were visited in order to assess standards of health and safety management. Our officers worked with officers from the HSE, Tonbridge & Malling (T&M) and Maidstone Councils

focussing on workplace transport, manual handling, slips and trips, work at height and asbestos.

- 'Asbestos Duty to Manage' project. 70 questionnaires were sent to businesses on a light industrial estate in Edenbridge and in the High Street. 24 were returned and in February three of our officers together three HSE officers targeted premises which hadn't returned questionnaires or where the responses were incomplete. As a result of inspections, three improvement notices relating to asbestos contraventions in HSE premises were served. A Kent wide press release was issued.

The following projects under the flexible warrant arrangement are planned for 2009/10:

- CAVE (Common Approach to Vehicle Enterprise) including tyre and exhaust and motor vehicle repair
- Asbestos Duty to Manage
- Workplace Transport Initiative (in conjunction with Kent Police, VOSA, DWP)

The aims of these projects is to deliver reduction in accidents, ill health and sickness absence resulting from work activities.

3.4 Skin Piercing

The team is also responsible for registering all premises in the district where acupuncture, electrolysis, tattooing, semi permanent skin colouring and cosmetic piercing take place.

A fee is charged for registration and prior to a business opening, it will be inspected to ensure that satisfactory safety standards are in place. We currently have 92 premises registered.

3.5 Accident at Work Reports

If there is an accident at work employers are under a legal duty under the The Reporting of Injuries, Diseases and Dangerous Occurrences Regulations 1995 (RIDDOR) to report details of the accident to the relevant Health and Safety enforcing authority (often the local authority EH team).

There are specific accidents which must be reported, these are work-related deaths, major injuries or over-three-day injuries, work related diseases, and dangerous occurrences (near miss accidents). Officers can access a database on a daily basis to obtain details of any accidents that have occurred in the District. The details are then assessed and a decision is made as to what course of action needs to be taken to investigate.

With some investigations evidence may need to be collected on site, witness statements taken, technical information gained and hence investigations can

take a considerable time to resolve whether finding out the facts, possibly requiring improvements and/or taking legal action.

Table 6. The number of RIDDOR reported accidents in Sevenoaks during 08/09

Fatalities	1
Major injuries	11
Over 3 day injuries	36
Public taken from site of accident to hospital	45
Work related diseases	1
Dangerous occurrences	0
Non reportable	52

3.6 Smoke Free Enforcement

Our Smoke Free Officer continues to provide advice to businesses and carries out enforcement work as required.

Non compliance with legislation is noted during routine food safety, health and safety and licensing visits and information given to the Smoke free Officer for appropriate action.

As a result of a successful bid for funding, we have been allocated £13,000 from KASH (Kent Alliance on Smoking and Health). The funding will allow our Smoke Free Officer to target businesses which do not fall within the jurisdiction of SDC for health and safety enforcement as they come under the HSE who are not authorised for smoke free enforcement. The majority of these employees are manual/routine workers who are more likely to be smokers. This will be a pilot project to raise awareness and the results will be publicised to stimulate further action. The project will involve partnership working with HSE, the PCT (Primary Care Trust) and KASH.

Statistics will be reported to the Department of Health until 2010.

3.7 Infectious Disease Control

The Commercial team receives notifications of infectious diseases within the district. These come from different sources including the Health Protection Agency, Doctors, the public, businesses and other local authorities. The authority will work in close liaison with the Consultant in Communicable Disease Control (CCDC).

The diseases include food poisonings such as salmonella, campylobacter and E Coli 0157 and gastroenteritis and other diseases including Dysentery, Hepatitis, Rubella and Tuberculosis.

All victims of notifiable disease within the authority are contacted either by letter, phone or in person. On average approximately 220 notifications are received per year.

The team has a responsibility to prevent the spread of illness within the community and to try and establish possible causes. Advice is given to the patient on how to prevent the spread of disease within the home. Children with symptoms may need to be excluded from school and adults with symptoms who work in the food industry or with vulnerable groups may need to be excluded from work.

In the case of significant food poisoning outbreaks within the area, all the victims will be interviewed, faecal samples taken, and a list of contacts obtained. The suspect premises will be visited and appropriate action will be taken. This can include closure of the premises whilst investigations take place. This may involve work outside office hours and the combined effort of the team.

Registration of Cooling Towers and Evaporative Condensers: All premises where cooling towers and evaporative condensers are situated must register with the local authority under The Notification of Cooling Towers and Evaporative Condensers Regs 1992. The prime purpose of this is to identify potential areas that could give rise to spread of infectious diseases, e.g. Legionella, and to ensure that preventative measures are taken to eliminate the risk of such infection arising to employees and the public. Our register has recently been revised and updated.

3.8 Safer Food Better Business

In January 2006 new EU legislation came into force where an obligation was imposed on food business proprietors to implement a documented food safety management system in all food premises.

This meant that businesses now have to carry out a hazard analysis or HACCP plan (Hazard Analysis Critical Control Point) associated with the food safety handling practices and procedures of the business. For many independent or smaller food businesses this could prove to be both confusing and time consuming for proprietors and staff.

The Food Standards Agency introduced a campaign called 'Safer Food Better Business' (SFBB). This is a toolkit designed for use by small businesses and offers both a practical and simple approach to complying with the law. SFBB guides businesses in documenting their exact procedures and identifying the measures needed to prevent incidents such as food poisoning.

Following participation in the successful Kent SFBB project which concluded in March 2008, officers continue to provide advice and guidance when necessary to new businesses and business that did not benefit from seminars previously held.

We, in partnership with T&M, Dartford, Tunbridge Wells (T.Wells) and West Kent College (WKc) have submitted a bid for further funding to the Food Standards Agency (FSA) to support a project which will provide businesses that are not achieving 'broad compliance' with legislation the best opportunity

to improve their risk rating. It is also intended to introduce SFBB as a practical toolkit to catering students in the college to encourage sustainability of this type of food safety management system in the premises which they work. If the application for funding is successful the project will run from July 09 to March 2010.

3.9 Training Partnership

A training partnership was launched in October between WKc, SDC, T&M and TWells Councils. This has enabled food business operators within these districts to benefit from a wide range of food safety and health & safety courses in a good choice of locations. Six food hygiene courses have been provided at Sevenoaks to date and all courses have been very well attended. Eight 'Level 2 Award in Food Safety in Catering' courses are planned at Sevenoaks between April 09 and September 10.

3.10 'Scores On The Doors'

Following a routine food hygiene inspection, a hygiene score is provided by the officer which is then converted to a star rating and displayed on a public website, www.scoresonthedoors.org.uk. This scheme is called "Scores on the Doors" (SOTD) and was launched in January 2008. As at 30th April 2009 there are 524 inspection results on the SOTD site.

The scheme has resulted in a number of proprietors becoming more interested in how the inspection programme works and in how they can improve their star ratings. This has helped to promote Safer Food Better Business, and other food safety management systems, and hence compliance with the law.

Table 8. Scores on the Doors - Food safety inspection results

Stars	Description	No. of premises in the category
5	Excellent	54
4	Very good	161
3	Good	165
2	Broadly complaint	65
1	Poor	58
0	Very poor	21

The results so far indicate that a vast majority of premises in the SDC area, (over 80%), are being run in at least broad compliance with the law. More than 70% are in categories good and above. This year we aim to focus on 0 and 1 star premises to raise their standards. For more information please refer to the website above.

3.11 'Reach for the Stars' seminar

A training day was organised in partnership with T&M and Maidstone Councils to help businesses improve their understanding of SFBB and how to

comply with food legislation. 59 food handlers from 24 businesses within SDC attended and very positive feedback was received. It is intended to run this event again in November.

3.12 Food Sampling

The food safety team routinely carry out food sampling to monitor the safety of food prepared and/or on sale in the district.

The Health Protection Agency regularly issues a sampling protocol and local authorities are asked to participate in a national survey and take samples of specific foods. Thereafter these are submitted to the designated HPA laboratory for examination. This authority is also an active member of The Kent Sampling Group.

Sevenoaks District Council also takes samples for 'The Kent Shopping Basket'. Foods that are of interest are chosen by the members of the sampling group and each Kent authority participates in this programme. As part of the sampling programme we aim to meet the national target set by the Food Standards Agency which requires that imported food makes up 10% of all food samples taken.

Sampling can also be necessary as a result of an officer's concern during a routine food hygiene inspection or following a complaint, e.g. surfaces may be swabbed if cleaning is an issue.

Samples can also be taken upon the receipt of a food complaint where the item of food in question is submitted to the laboratory for examination or analysis or when any left over food is suspected of being a possible cause of food poisoning.

Table 9. Number of food samples taken

2006/07	92
2007/08	82
2008/09	115

3.13 Private Water Supplies

The Commercial Team has a statutory obligation to sample private water supplies in the district. There are currently six such supplies in the district that are sampled on a regular basis to ascertain the wholesomeness of the supply and to ensure that it is not detrimental to health.

Upon receiving the results it is necessary to ascertain if the water complies with the regulations and advise the owner of the premises or the company controlling the supply. If it is concluded that the water exceeds the stated

parameters, any necessary action is taken which can include the advice to boil water before use as an interim measure whilst the situation is resolved; fitting a UV filter or taking formal action by the serving of a legal notice on the owner of the supply.

Table 10. Number of private water samples taken

2006/07	23
2007/08	11
2008/09	25

The new 'Private Water Supplies Regulations 2008' are expected to come into force 1st July 2009. These regulations are expected to introduce many deviations from the P W Regs 1991 currently in force. It is anticipated that a large amount of preparatory work will be required by the team in order to carry out its function as the enforcing authority and this will require liaison with Environmental Protection and Private Sector Housing.

25 routine private water samples are scheduled to be taken during 2009 with further samples being taken if necessary following any unsatisfactory result and subject to requirements of the new regulations.

4.0 Team Achievements April 2008 – April 2009

- EH teams continue to exceed all Local Performance Indicators
- External funding achieved to continue Smoke Free work
- Organising and chairing the Brands Hatch Safety Advisory Group Meetings
- Partnership working with the Health & Safety Executive and other Kent authorities to enable health & safety enforcement work across boundaries.
- Provision of a training day to help improve 'star' rating of food businesses
- A training partnership to provide a range of food and health & safety courses to businesses
- The 'Scores on the Doors' website displays the star rating of approx 524 food businesses
- Continued compliance and achievement of Air Quality programme
- Being commended by Defra for the Air Quality Action Plan 2008/9
- Being awarded air quality grants worth £35,500 by Defra towards Air Quality Action Plan objectives and monitoring costs..
- There was a 72% drop in noise complaints during the first year of operation of the Brands Hatch Noise Management Plan
- Continue to be a leading partner on a national Motorsports forum and represent the CIEH on an Institute of Acoustics working group on motor sport noise
- Improved corporate profile and role in tackling anti social behaviour
- A successful Joint EH Management Partnership has been established between Dartford and Sevenoaks

For further information about any of the above, please contact:

Alex Dawson
Assistant Environmental Health Manager – Environmental Protection Team
01732 227263

Glenys Shorrick
Assistant Environmental Health Manager – Commercial Team
01732 227187

Appendix A

Environmental Health Organisational Structure

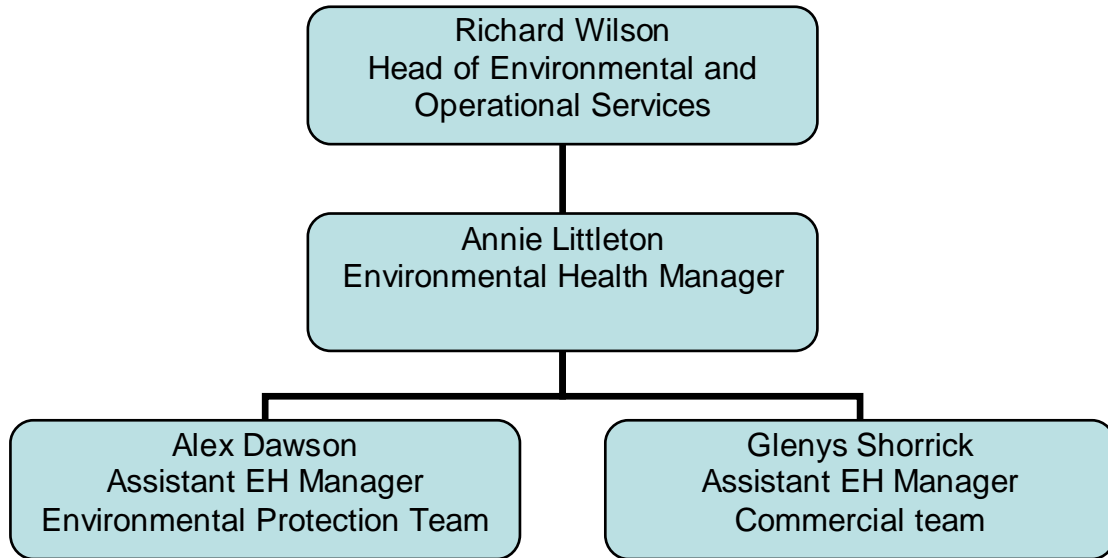

Environmental Protection Team

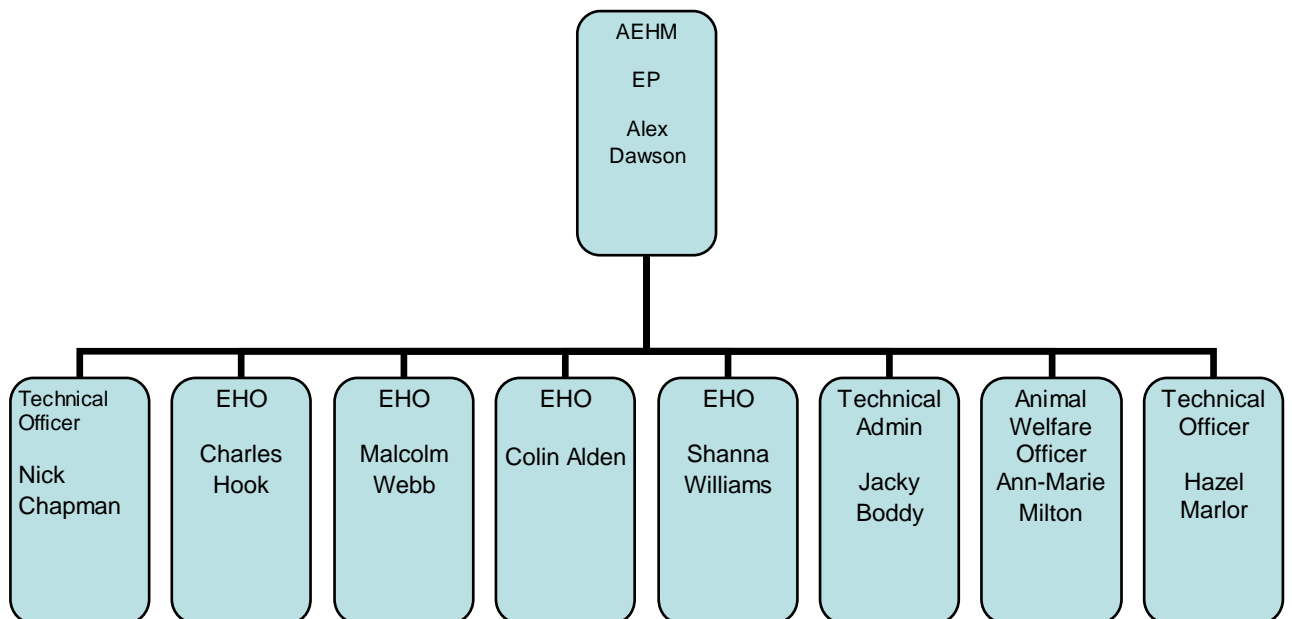

Commercial Team

